

TRICON STEEL-CON PIPE SYSTEM

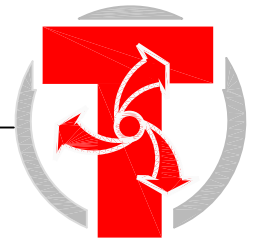

For Applications Up To 450° F Below And Above Ground

- Cogeneration Condensate
- High Temp. Hot Water
- Steam

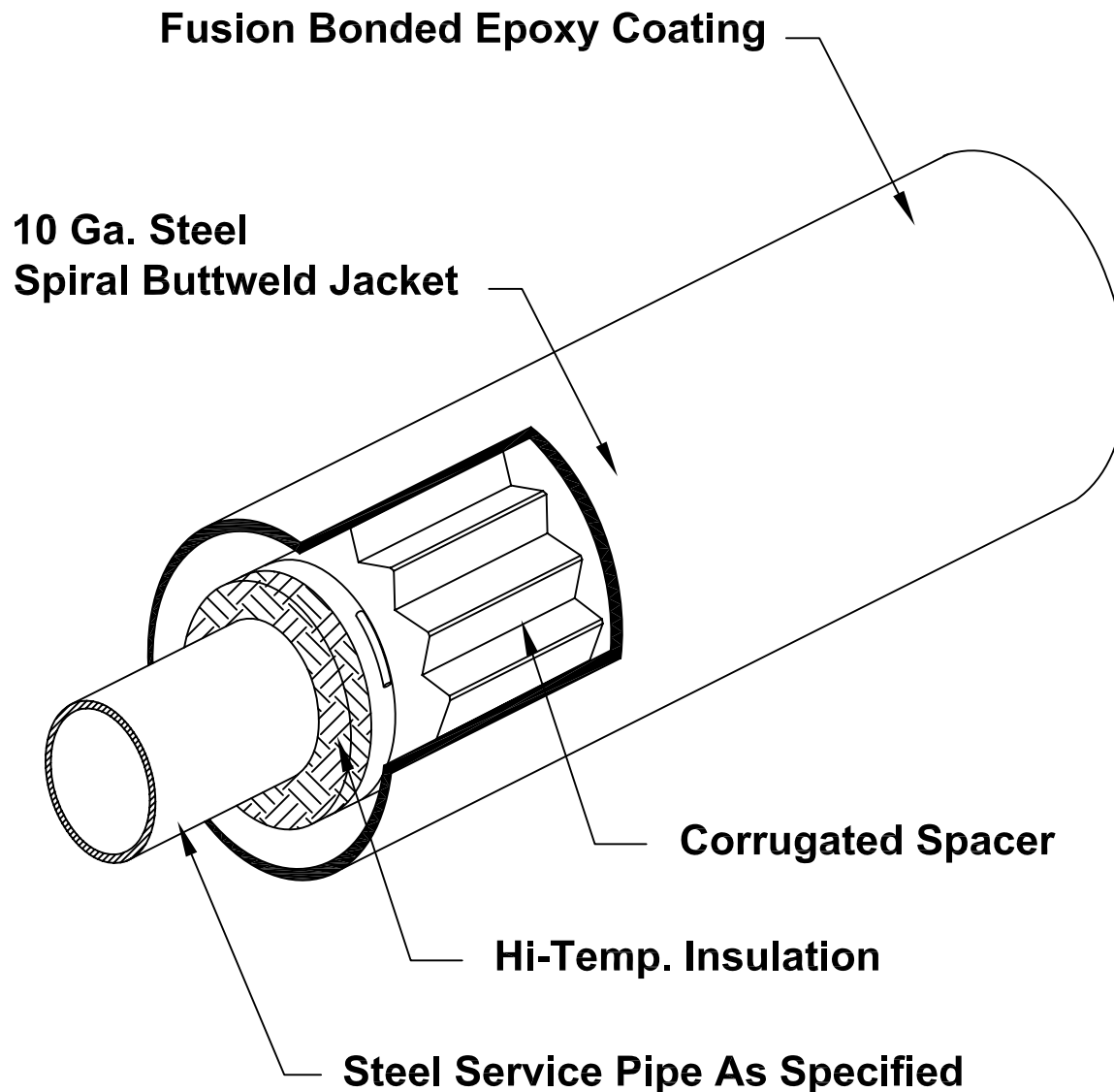

TRICON
Piping Systems, Inc. ®

P.O. Box 361, Canastota, New York 13032
Tel: 315.697.8787 Fax: 315.697.8788

Pipe Size	Insulation Thickness	Steel Conduit O.D.
1"	1½"	6.63"
2"	1½"	8.63"
3"	2"	10.75"
4"	2"	10.75"
6"	2"	14.00"
8"	2½"	16.00"
10"	2½"	18.00"
12"	2½"	20.00"

Based on a minimum 3'-6" burial depth, 353° operating temperature, 50°F ground temperature and soil conductivity of 15 BTU-IN/HR-F²-°F and mineral wool insulation.

Service Pipe:

Carbon steel service pipe shall be standard weight A53 ERW or A106 seamless beveled for welding. Condensate return piping shall be Schedule 80. All joints for pipe 2 ½" and larger in size shall be butt-welded. Sizes 2" and smaller shall be socket welded. Straight lengths of piping will be supplied with 6" of piping exposed at each end for field joint fabrication. Where possible, piping lengths shall be supplied in 40 Ft. random lengths.

Insulation:*

Service pipe insulation shall be fiberglass, mineral wool, calcium silicate or cellular glass. The insulation will be held in place by stainless steel bands on 18-inch centers. The insulation shall be applied to a thickness as specified on the contract drawings.

Service Pipe Supports:

The service pipe within the inner-conduit shall be supported at not more than 10 feet intervals. The supports shall be designed to allow for continuous airflow and draining of the conduit system. The insulated service pipe shall not bear directly on the steel support and shall be insulated throughout.

Outer Conduit:

The outer conduit shall be a smooth wall, spiral welded or electric resistance welded steel pipe conforming to ASTM Specification A-139. The conduit shall be of thickness as listed below.

<u>Conduit Size</u>	<u>Conduit Thickness</u>
6" – 26"	10 Gauge
28" – 36"	06 Gauge
38" - 42"	04 Gauge

Outer Conduit Coating:

Conduit exterior shall be factory coated with a Fusion Bonded Epoxy with a melting point of 500°F. No glass wrap or filler materials shall be used in the epoxy. All exterior surfaces of the conduit shall be shot blasted prior to the application of the coating. The fusion bonded epoxy coating shall confirm to the following ASTM Standards:

Sheer Strength and Adhesion	ASTM D1002
Salt Crock	ASTM G8
Hardness	ASTM D1474
Impact Test	ASTM G14
Abrasion Resistance	ASTM D1044

Fusion Bonded Epoxy is a N.A.C.E & N.A.P.C.A. Approved Corrosion Coating

Conduit Field Closures:

Conduit field joint closures shall consist of a cylindrical 10-gauge sleeve having one (1) horizontal split which the installing contractor will weld in the field. After welding and air testing in the field, the metal sleeve will be covered and protected with polyethylene heat shrink material having a minimum thickness of 60 mils.

Sub-Assemblies:

Fittings, end seals and anchors shall be factory manufactured to prevent the ingress of moisture into the piping system. All sub-assemblies shall be designed and manufactured to allow for complete draining, drying and testing of the conduit system. All fittings larger than 2" will be made with long radius weld fittings and shall be the same wall thickness as the service piping.

Expansion Loops and Elbows:

Expansion loops and elbows shall be factory manufactured in the same manner as the straight lengths of piping. Loops and elbows shall be sized and designed to permit thermal movement of the service pipe without damage to the insulation.

Tricon Piping Systems, Inc.
P.O. Box 361
Canastota, NY 13032

Tel: 315-697-8787
Fax: 315-697-8788
www.triconpiping.com

Installation:

No Piping shall be installed in standing water. Trenches shall be maintained dry until final field closure is complete. The installing contractor shall handle the piping system in accordance with the directions furnished by the manufacturer and as approved by the architect and engineer. The service piping shall be hydrostatically tested to 1-1/2 times the operating pressure, or as specified in the contract documents. The inner conduit shall be air tested at 15 psig. The test shall be maintained for a minimum time of 1 hour. Holiday testing of the conduit coating shall be the responsibility of the installing contractor and will be done in accordance with directions furnished by the manufacturer. All holidays shall be repaired and retested. **EXERCISE DUE CARE WHEN INSTALLING AND TESTING THE PIPING SYSTEM**

Backfill:

A 4-inch layer of sand or fine gravel, less than 1/2" in diameter, shall be placed and tamped in the trench to provide uniform bedding for the **Steel-Con** system. Once the system is in place, the trenches shall be carefully backfilled with similar material and hand tamped in 6" layers until a minimum of 12" above the top of the preinsulated pipe has been achieved. The remainder of the backfill shall be void of rocks, frozen earth and foreign material. The trench shall be compacted to comply with H-20 Highway loading.

Accessories:

- Heat Tracing
- Leak Detection
- Cathodic Protection

System Options:

- Contact your Tricon representative for available sizes and system options.

* Insulation thickness will vary depending on the type of insulation specified and the operating temperature.

Tricon Piping Systems, Inc.
P.O. Box 361
Canastota, NY 13032

Tel: 315-697-8787
Fax: 315-697-8788
www.triconpiping.com



TRICON

Piping Systems, Inc. ®

P.O. Box 361, 2 Technology Blvd. Canastota, NY 13032

Tel: (315) 697-8787 Fax: (315) 697-8788

Fusion Bonded Epoxy Corrosion Coating

Product Description:

Fusion-Bonded Epoxy Coating is a one-part, heat curable, thermosetting epoxy coating powder designed for corrosion protection of pipe.

Temperature Operating Range:

The Fusion Bonded Epoxy coating, when properly applied, should perform in a satisfactory manner on pipelines operating between -100°F/-73°C to 230°F/110°C. For temperatures between +170°F/77°C to 230°F/110°C, laboratory tests indicate that the thicker coatings may improve the service capability. However, it is difficult to accurately predict field performance from the laboratory data due to the wide variation in actual field conditions. Soil types, moisture content, temperatures, coating thickness and other factors specific to the area all influence the coating performance and the upper temperature operating limit.

Properties:

Property	Value
Specific Gravity:	
Film	1.36
Powder	1.44
Coverage based on film	141 ft ² /lb/mil (0.735 m ² /kg/mm)
Color	Blue-Green
Gel time @ 400°F/ 204°C	17 seconds ± 20 %
Cure time @ 450°F/ 232°C	90 seconds

Testing Data:

Property	Test Description	Typical Value
Impact	ASTM G14 (modified)	
	1/8 in (3.2 mm) thick plate	160 in•lbs (18.1 J)
	3/8 in (9.5 mm) thick plate	59 in•lbs (6.7 J)
Cathodic Disbondment	CAN/CSA-Z245.20-12.8	
	48 hours, 1.5 volt, 3% NaCl 149°F/65°C	2.3 mm r
	28 day, 1.5 volt, 3% NaCl 73°F/23°C	2.5 mm r
	28 day, 1.5 volt, 3% NaCl 149°F/65°C	4.9 mm r
Hot Water Resistance	24 hours, CAN/CSA-Z245.20-12.14, 203°F/95°C	1 rating
	48 hours, CAN/CSA-Z245.20-12.14, 167°F/75°C	1 rating
Bendability (Mandrel Bend)	<u>Temperature</u>	<u>°/PD</u>
	73°F/23°C	<10.5
	-22°F/-30°C	<19.1
		>3.0
Compressive Strength	ASTM D 695	>10,000 psi (705 kg/cm ²)
Penetration	ASTM G 17	0
	-40° to 200°F/-40° to 93°C	
Thermal Shock	-320° to 310°F/-195° to 154°C	No visible effects
	Coated pipe	10 Cycles
Dielectric Strength	1180 V/mil (46 kV/mm)	

Note: The typical values in this data sheet are based on lab prepared samples. Values shown are not to be interpreted as product specifications.



TRICON

Piping Systems, Inc. ®

P.O. Box 361, 2 Technology Blvd. Canastota, NY 13032

Tel: (315) 697-8787 Fax: (315) 697-8788

Fusion Bonded Epoxy Corrosion Coating

Application of Fusion Bonded Epoxy on pipe:

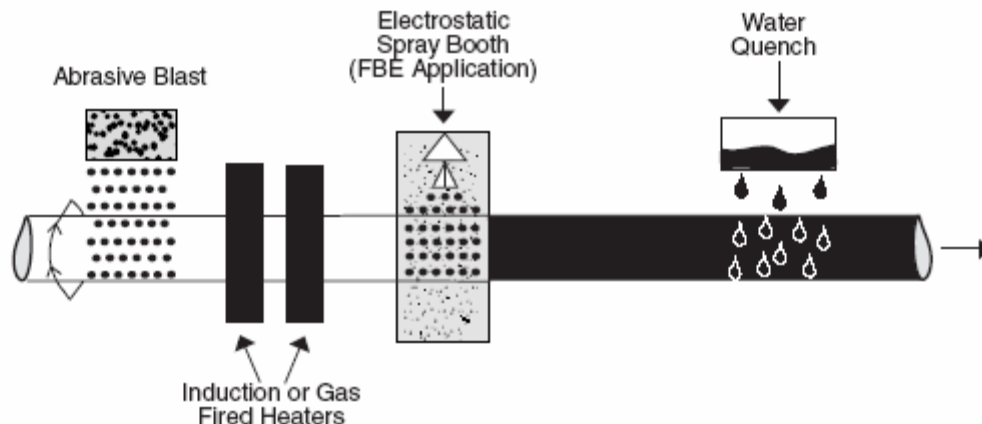

1. Pipe is cleaned and blasted to a near white metal finish with a nominal 2 mil anchor pattern.
2. Pipe is uniformly heated to a temperature between 450°F – 488°F by either gas fired forced air, electrical induction or infrared.
3. Pipe now passes through the coating booth where the fusion bonded coating is uniformly sprayed using electrostatic induction, onto the heated pipe.
4. Residual heat in the pipe helps cure the coating prior to cold water quenching.
5. Coated pipe is inspected for continuity with conventional search electrodes of either steel springs or conductive rubber. Repairs will be made with a hot melt patch stick or a two part epoxy resins. Thickness of coating shall be checked with calibrated gauges.

Cathodic Protection:

Fusion Bonded Epoxy on steel is easily compatible with cathodic protection systems utilizing galvanic anodes or impressed current type systems.

Notice:

This product literature and the recommendations for usage is intended for use by personnel having knowledge of industry accepted practice under normal operating conditions. Variations in environment, operating temperatures or extrapolation of data may cause unsatisfactory results. The information contained in this document is subject to change without notice.

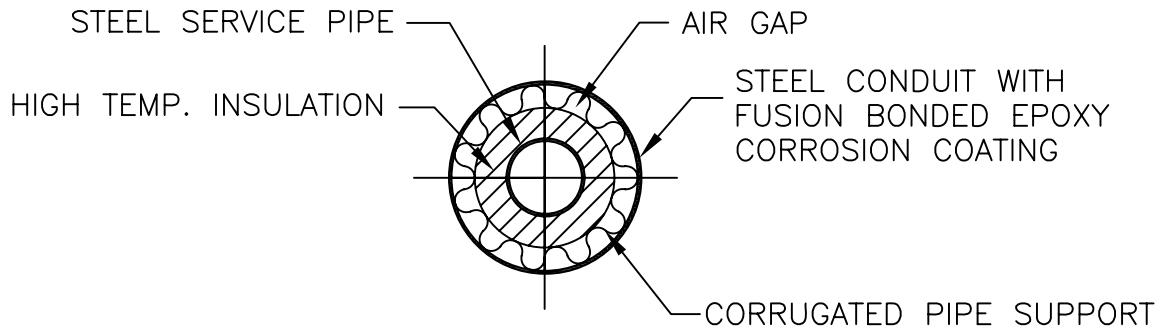

END VIEW
NOT TO SCALE

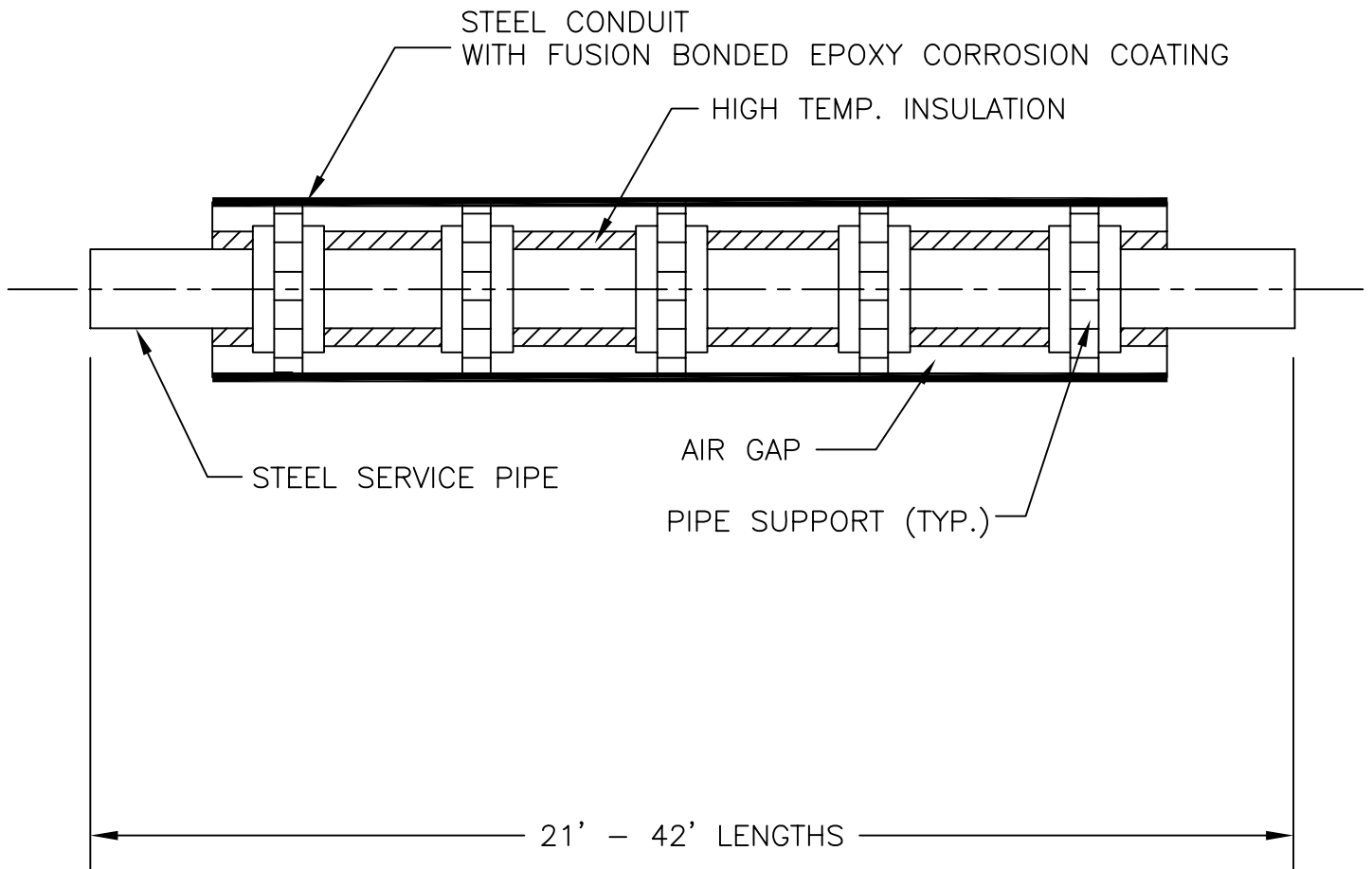

NOTE: FUSION BONDED EPOXY IS A N.A.C.E. & N.A.P.C.A. APPROVED CORROSION COATING

STEEL-CON STRAIGHT LENGTH DETAIL

TRICON STEEL-CON

Date: 03/09/06

Dwg. No.: SC-1

Rev.:



TRICON

Piping Systems, Inc.®

P.O. Box 361, Canastota, New York 13032

Tel: 315.697.8787 Fax: 315.697.8788

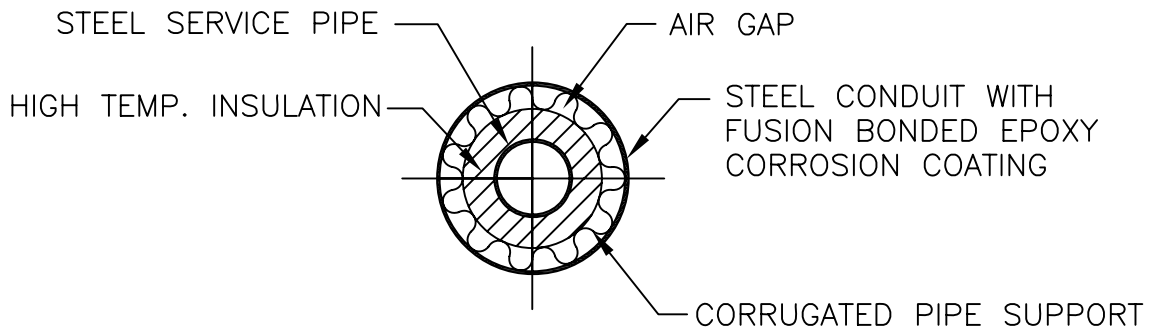

END VIEW
NOT TO SCALE

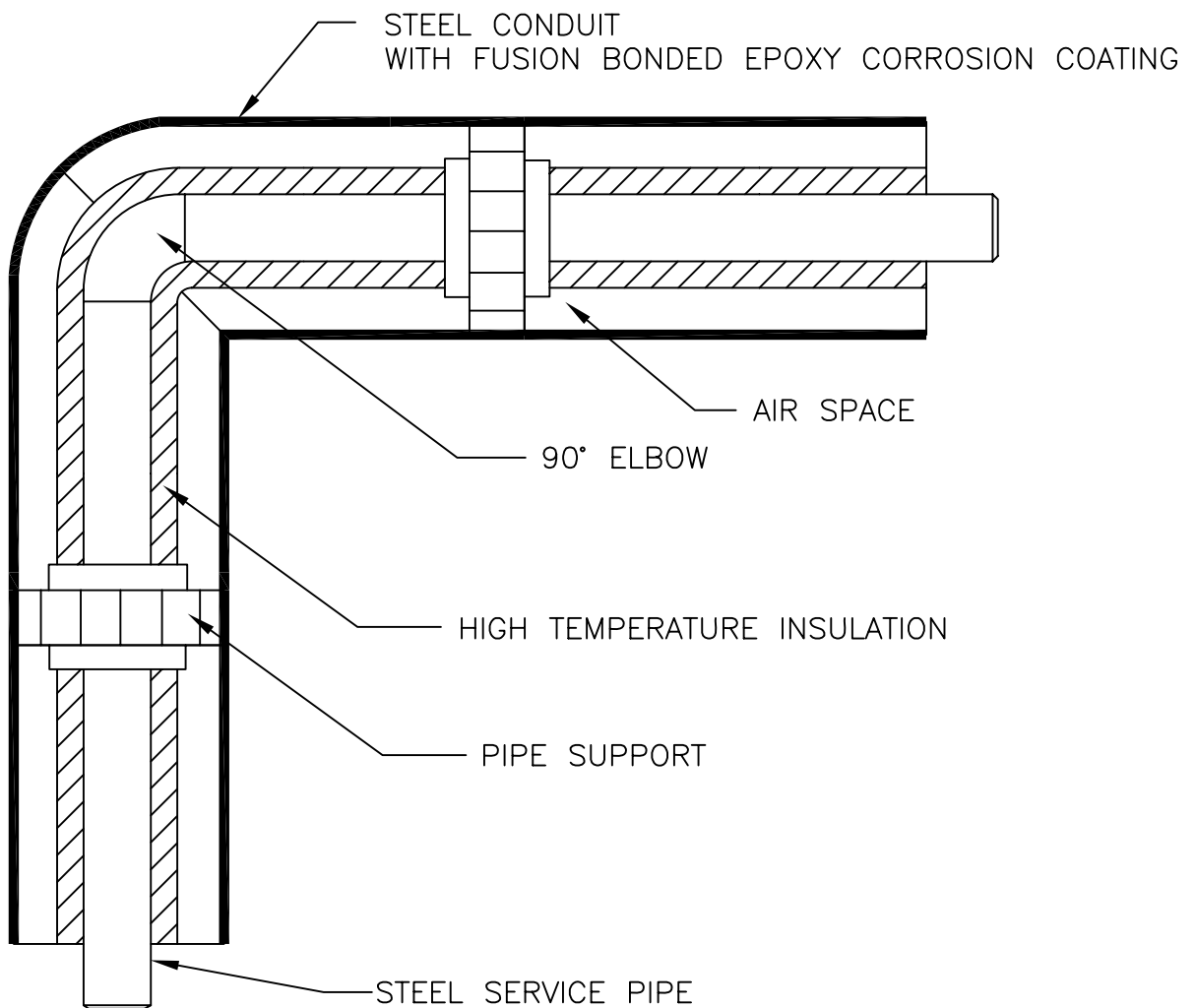

STEEL-CON 90° ELBOW DETAIL



TRICON

Piping Systems, Inc.®

P.O. Box 361, Canastota, New York 13032

Tel: 315.697.8787 Fax: 315.697.8788

TRICON STEEL-CON

Date: 03/09/06

Dwg. No.:SC-2

Rev.:

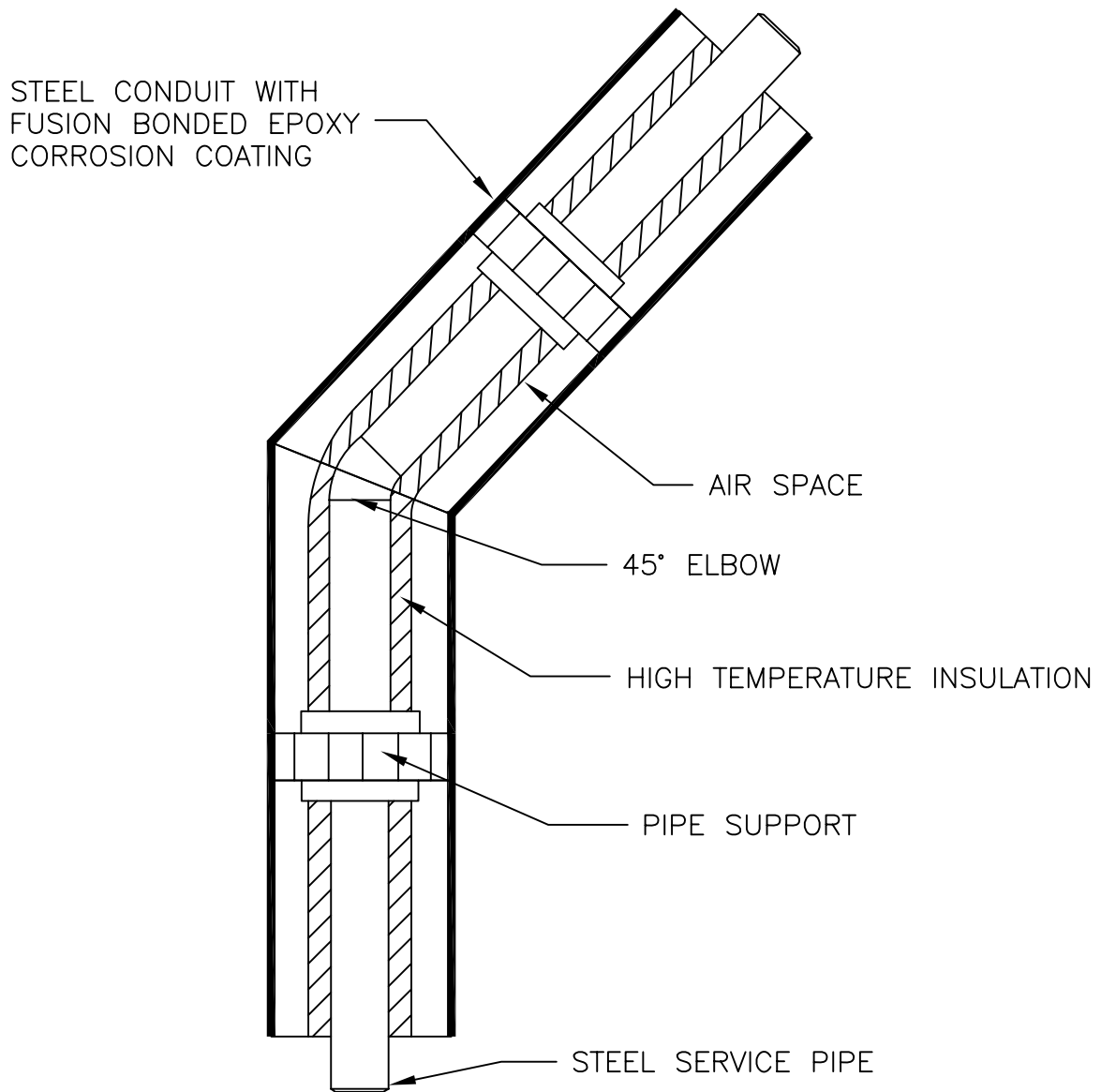
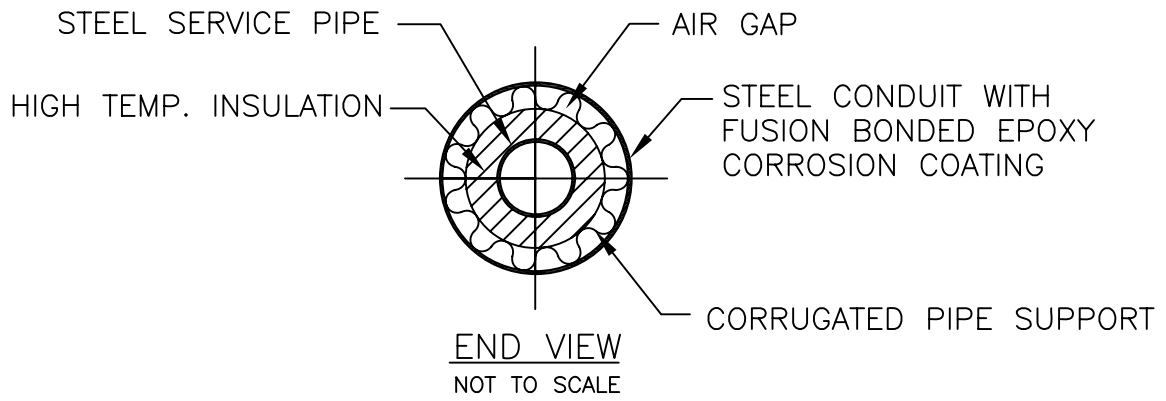

STEEL-CON 45° ELBOW DETAIL



TRICON

Piping Systems, Inc.®

P.O. Box 361, Canastota, New York 13032

Tel: 315.697.8787 Fax: 315.697.8788

TRICON STEEL-CON

Date: 03/09/06

Dwg. No.: SC-3

Rev.:

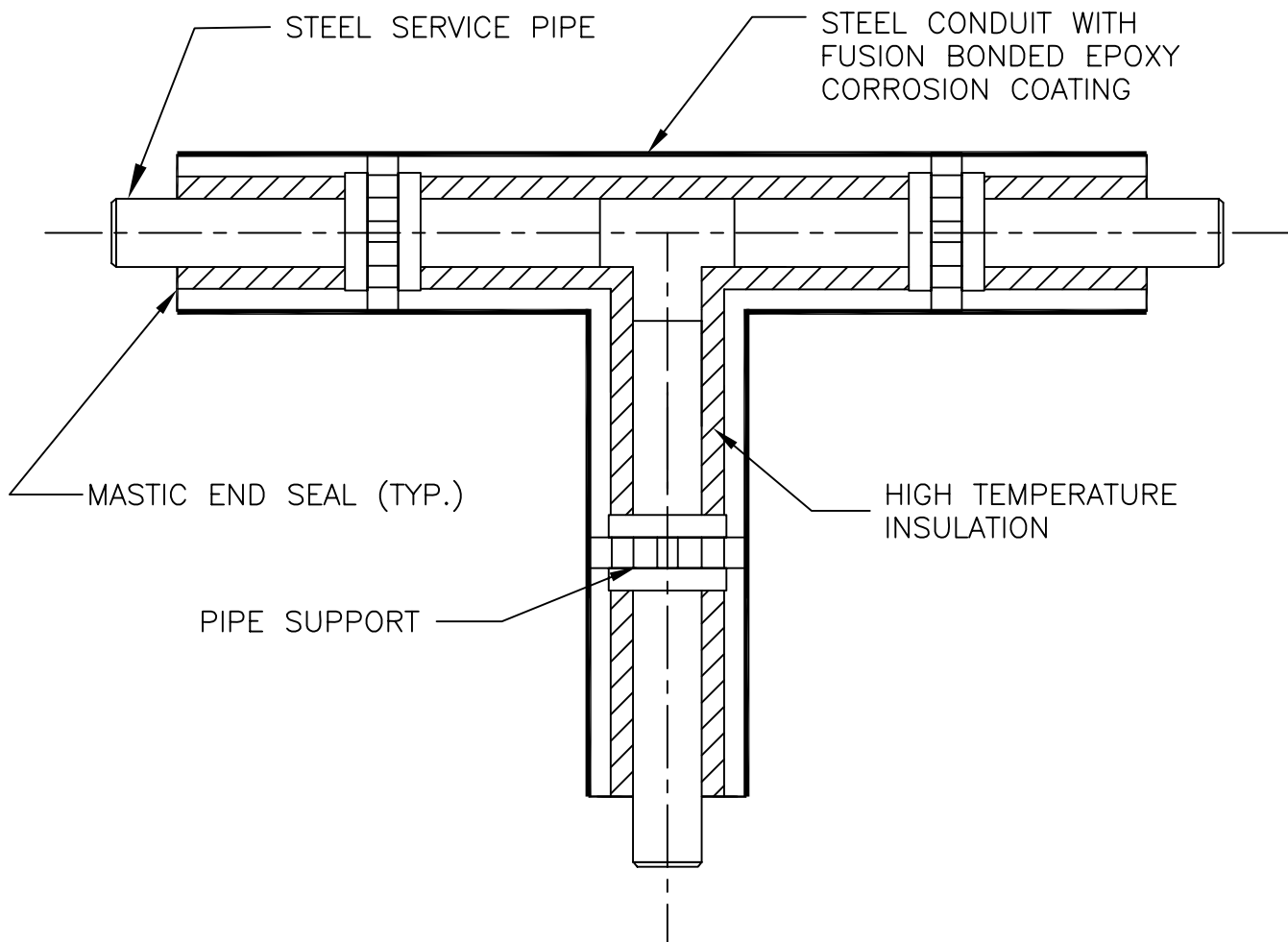
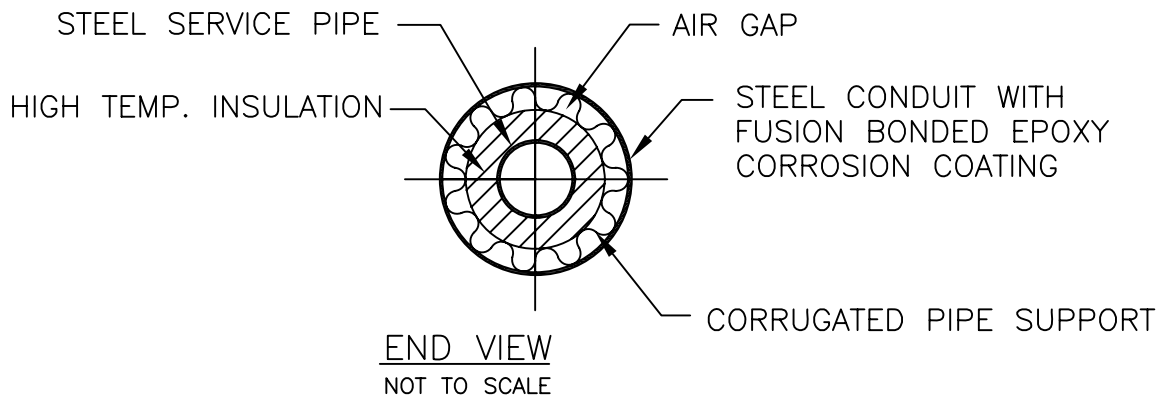

STEEL-CON TEE DETAIL

TRICON STEEL-CON

Date: 03/09/06 Dwg. No.: SC-4

Rev.:



TRICON
Piping Systems, Inc.®

P.O. Box 361, Canastota, New York 13032
Tel: 315.697.8787 Fax: 315.697.8788

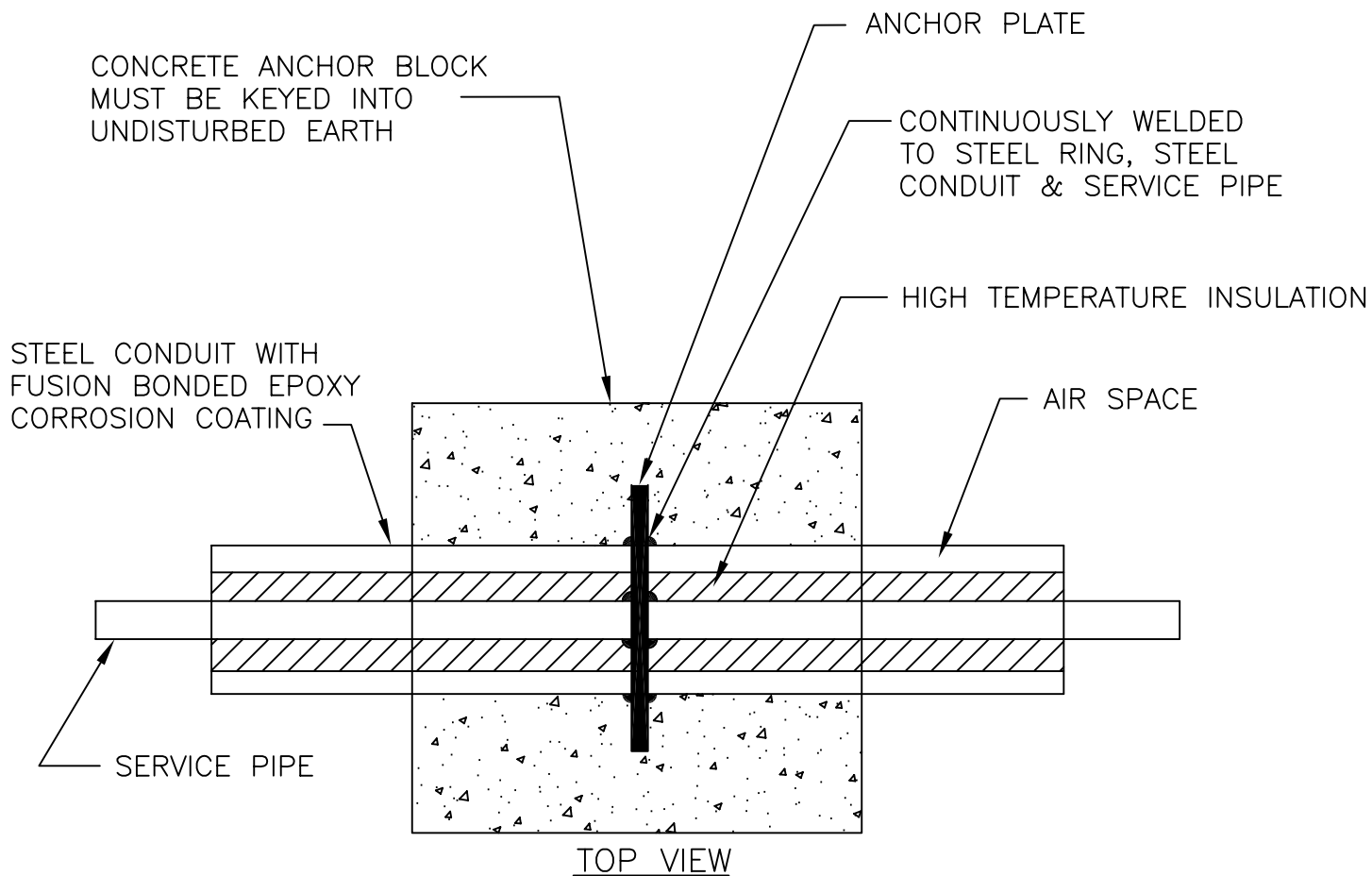

TOP VIEW

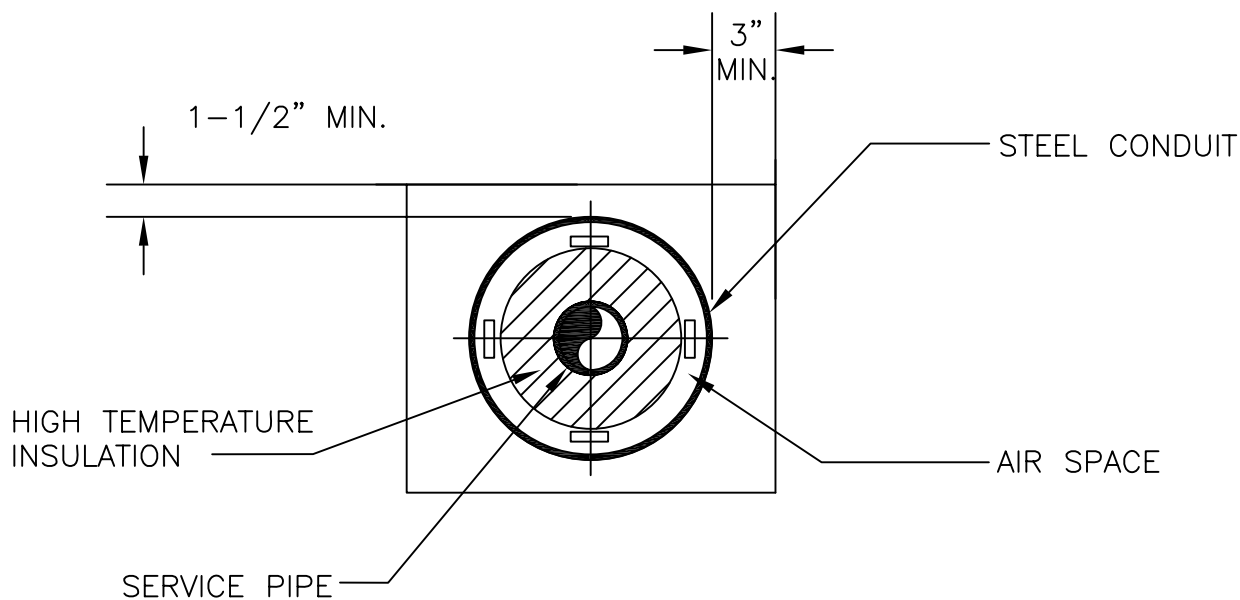

END VIEW
NOT TO SCALE

NOTE: CONCRETE ANCHOR BLOCK MUST BE KEyed INTO UNDISTURBED EARTH.

STEEL-CON ANCHOR DETAIL

TRICON STEEL CON

Date: 03/09/06

Dwg. No.: SC-5

Rev.:



TRICON

Piping Systems, Inc.®

P.O. Box 361, Canastota, New York 13032

Tel: 315.697.8787 Fax: 315.697.8788

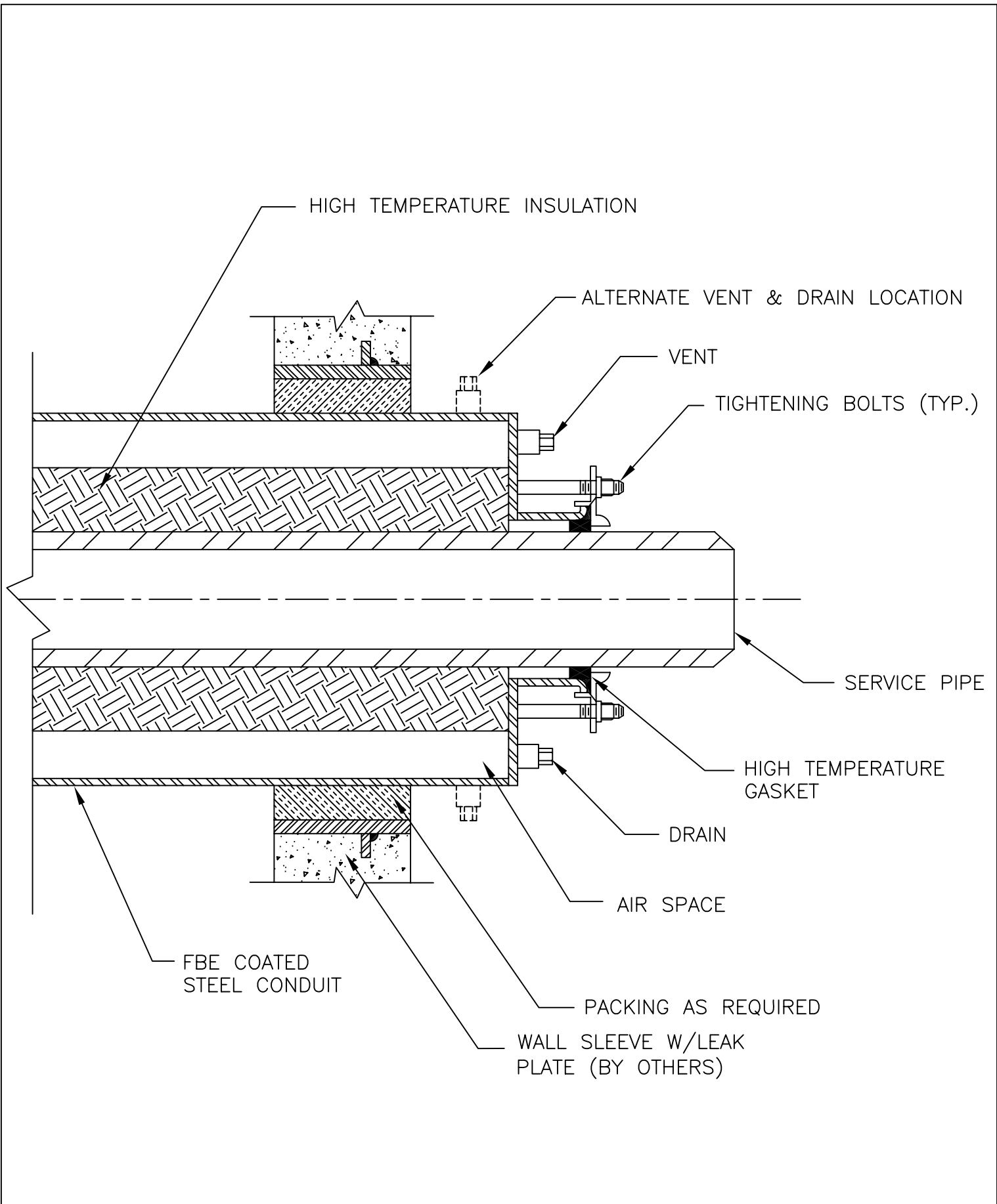

STEEL-CON GLAND END SEAL DETAIL

TRICON STEEL-CON

Date: 03/09/06

Dwg. No.:SC-6

Rev.:



TRICON

Piping Systems, Inc.®

P.O. Box 361, Canastota, New York 13032

Tel: 315.697.8787 Fax: 315.697.8788

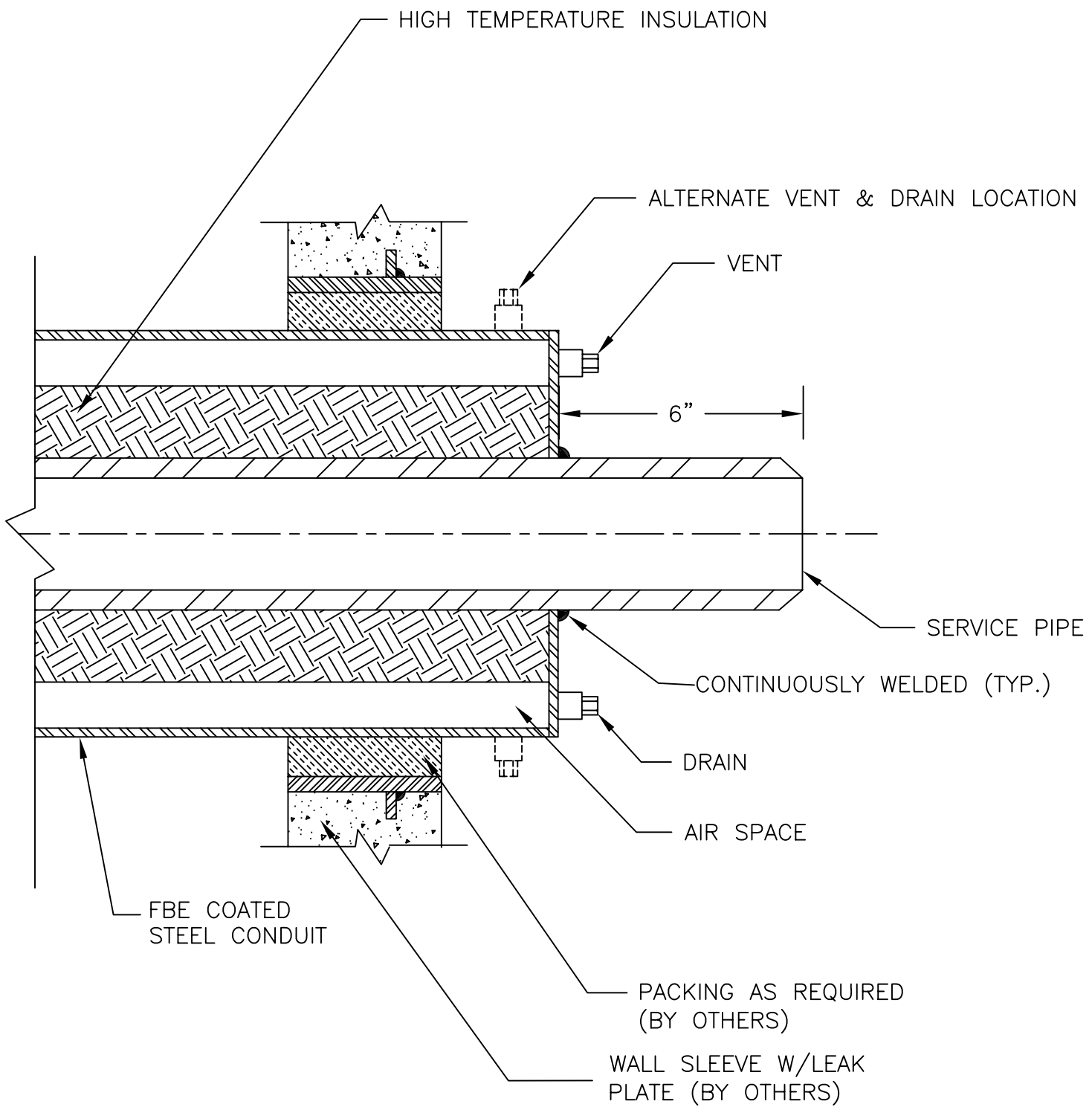

STEEL-CON WELD END SEAL DETAIL

TRICON STEEL-CON

Date: 03/09/06

Dwg. No.: SC-7

Rev.:



P.O. Box 361, Canastota, New York 13032
Tel: 315.697.8787 Fax: 315.697.8788

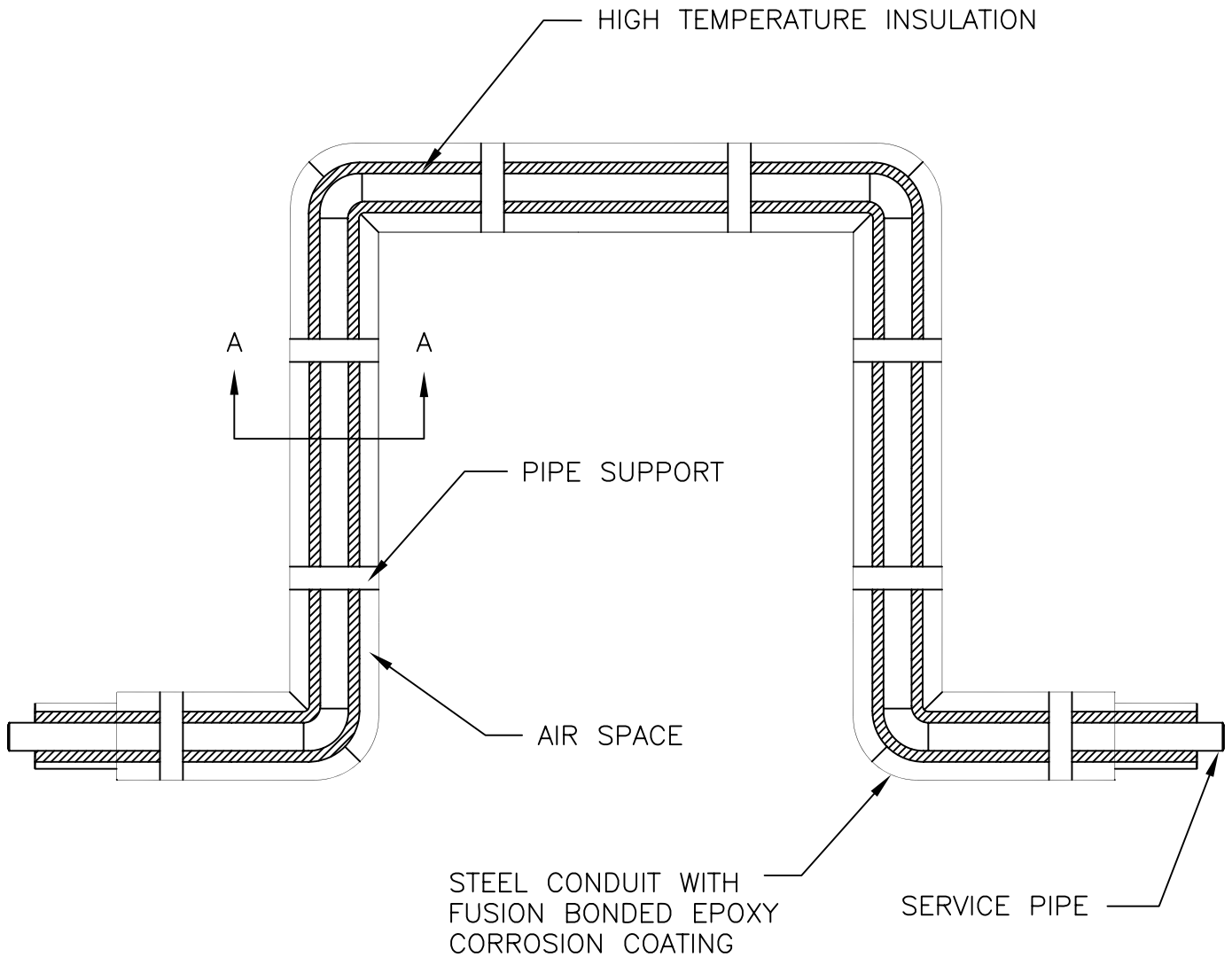
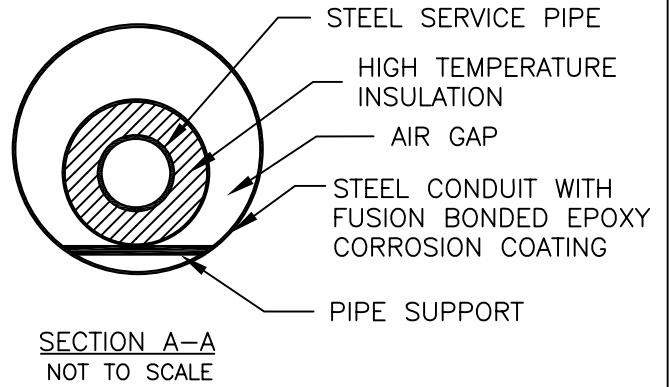
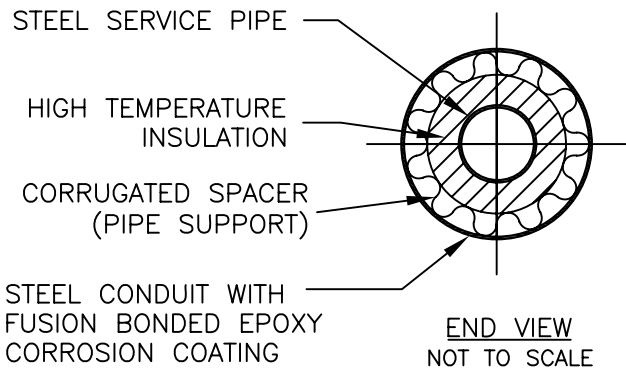

STEEL-CON EXPANSION LOOP

TRICON STEEL-CON

Date: 03/09/06

Dwg. No.:SC-8

Rev.:



TRICON

Piping Systems, Inc.®

P.O. Box 361, Canastota, New York 13032

Tel: 315.697.8787 Fax: 315.697.8788

WELDED IN FIELD
AFTER AIR TEST OF
CONDUIT (IF REQUIRED)

STEEL
CARRIER PIPE

WATERSHED

CONDUIT PUMP-OUT LINE

CARRIER PIPE
DRAIN LINE

5"
2"
1"

AS REQUIRED

SLOPE
DOWN

TEE

AIR SPACE

1" MAX.

STEEL CONDUIT WITH
FUSION BONDED EPOXY
CORROSION COATING

HIGH TEMPERATURE INSULATION

CONDUIT PUMP-OUT

SINGLE DRIP TEE ASSEMBLY WITH WATERSHED



TRICON

Piping Systems, Inc.®

P.O. Box 361, Canastota, New York 13032

Tel: 315.697.8787 Fax: 315.697.8788

TRICON STEEL-CON

Date: 03/09/06

Dwg. No. SC-9

Rev.:

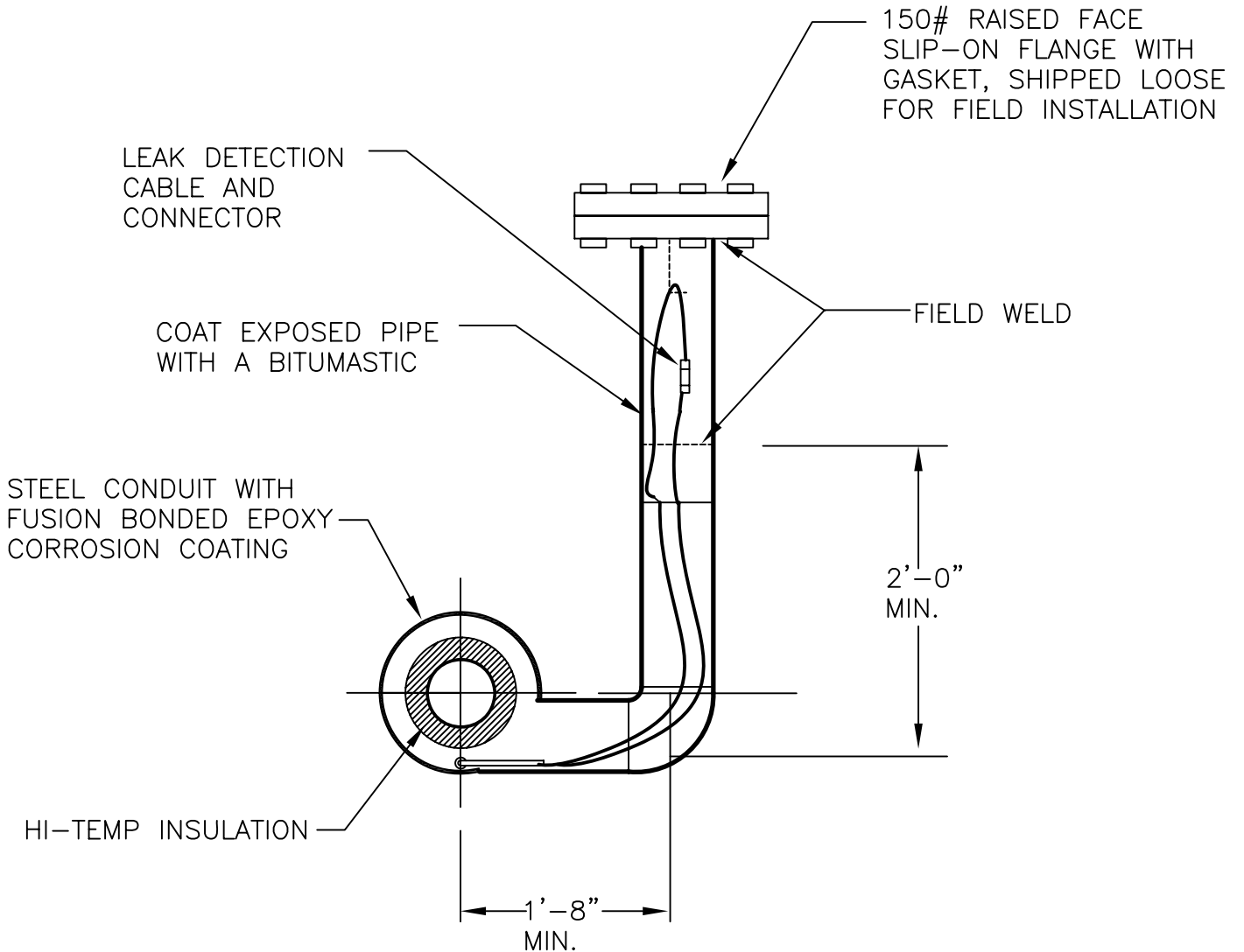

PULL PORT TEE DETAIL



TRICON STEEL-CON

Date: 03/09/06

Dwg. No.: SC-10

Rev.:

P.O. Box 361, Canastota, New York 13032
 Tel: 315.697.8787 Fax: 315.697.8788

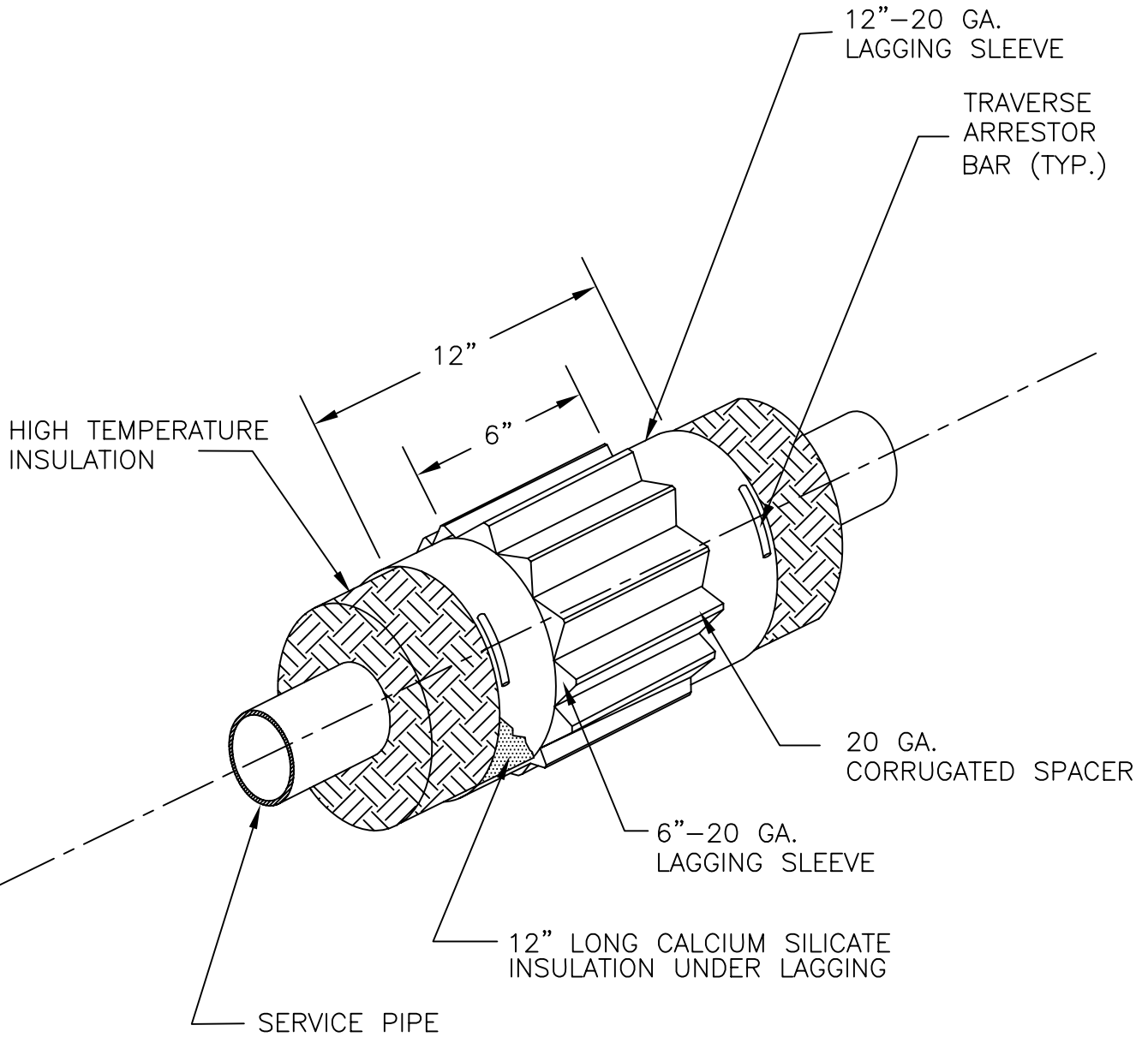

TRICON STEEL-CON PIPE SUPPORT DETAIL

TRICON STEEL CON

Date: 03/09/06

Dwg. No.: SCP-11

Rev.:



TRICON

Piping Systems, Inc.®

P.O. Box 361, Canastota, New York 13032

Tel: 315.697.8787 Fax: 315.697.8788

STEP 1

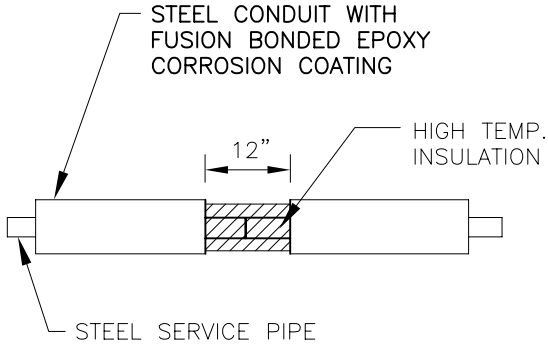

TEST ALL WELDED JOINTS AS REQUIRED. APPLY HIGH TEMPERATURE INSULATION AND SECURE IN PLACE.

STEP 2

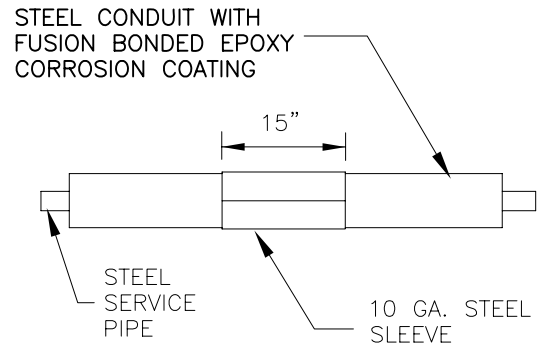

SLIDE 10 GA. SLEEVE INTO PLACE AND WELD WITH TWO CIRCUMFERENTIAL AND ONE HORIZONTAL WELDS

STEP 3

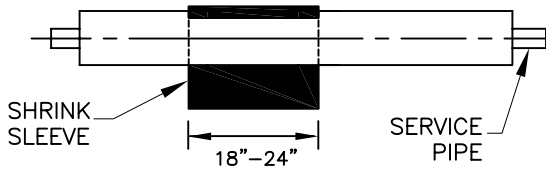

REMOVE RELEASE LINER OF SHRINK SLEEVE AND PLACE AROUND STEEL SLEEVE. OVERLAP THE SHRINK SLEEVE AT THE 10 TO 12 O'CLOCK POSITION. GENTLY HEAT BACKING SLEEVE & CLOSURE. PRESS THE CLOSURE FIRMLY INTO PLACE. GENTLY HEAT CLOSURE & PAT DOWN.

STEP 4

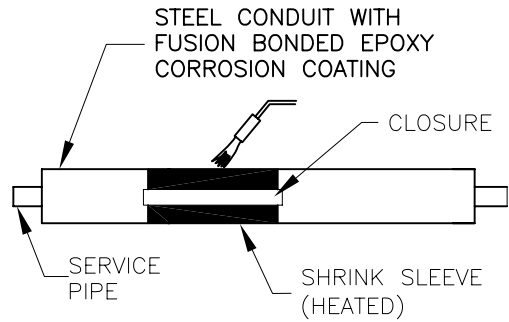

WITH LOW YELLOW FLAME, HEAT SHRINK SLEEVE FROM THE MIDDLE TOWARD EACH SIDE OF THE SLEEVE UNTIL RECOVERY IS COMPLETE. SHRINKING HAS BEEN COMPLETED WHEN ADHESIVE OZZES FROM SIDES. AVOID EXCESSIVE HEAT TO THE OVERLAP AREA.

STEP 5

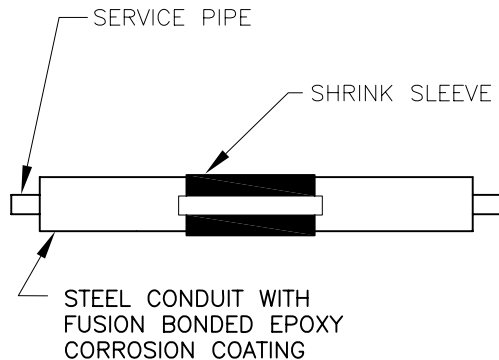

WAIT FOR SHRINK SLEEVE TO COOL BEFORE BACKFILLING. FIELD JOINT IS NOW COMPLETE.

STEEL-CON FIELD JOINT DETAIL



TRICON

Piping Systems, Inc.®

P.O. Box 361, Canastota, New York 13032

Tel: 315.697.8787 Fax: 315.697.8788

TRICON STEEL-CON

Date: 03/09/06

Dwg. No. SC-12

Rev.: